

Drawn by: R. Merchant  
**ME 218C Smart Product Practice**  
 Sheet: /  
 File: Circuits\_lab10.sch  
**Title: Audio Modem Circuit**

Size: USLetter	Date:	Rev: 1
KiCad E.D.A. kicad (5.0.1)-4		Id: 1/3

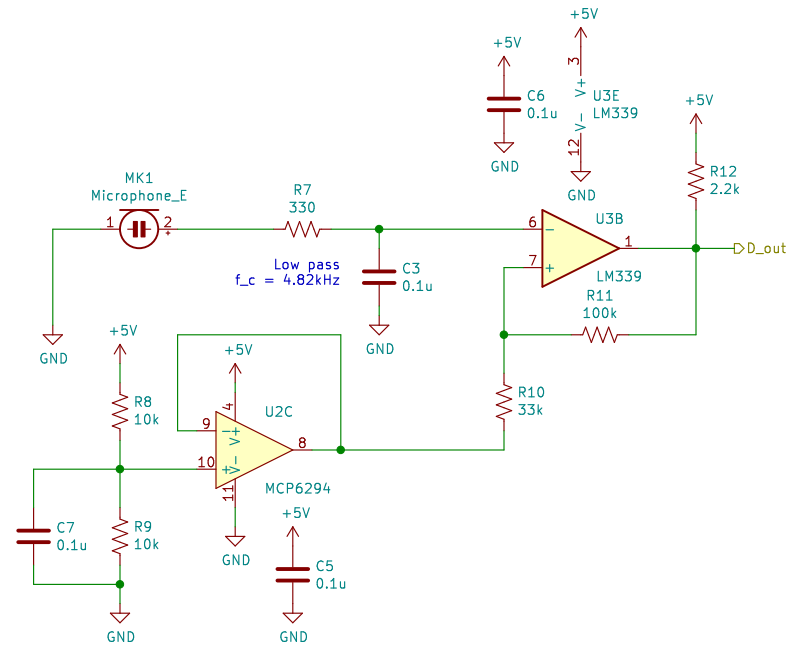

Drawn by: R. Merchant  
**ME 218C Smart Product Practice**  
 Sheet: /Input/  
 File: input.sch

**Title: Microphone Input Circuit**

Size: USLetter	Date:	<b>Rev: 1</b>
KiCad E.D.A. kicad (5.0.1)-4	Id: 2/3	

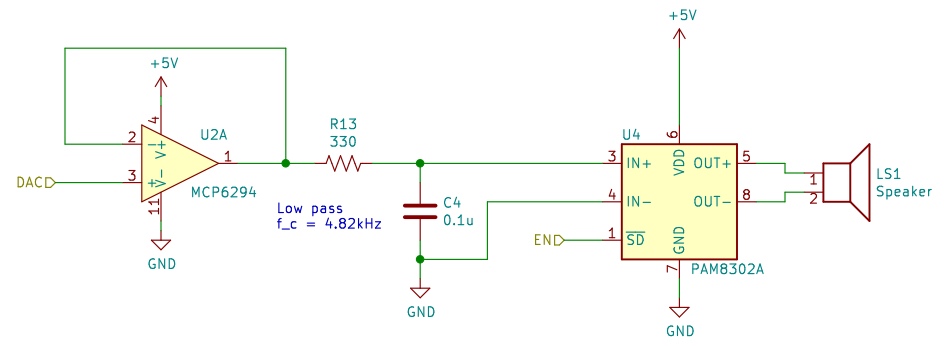

Drawn by: R. Merchant  
**ME 218C Smart Product Practice**  
 Sheet: /Output/  
 File: output.sch

**Title: Output Speaker Circuit**

Size: USLetter	Date:	<b>Rev: 1</b>
KiCad E.D.A. kicad (5.0.1)-4		